



INDOOR



LED BRIDGELUX

P50

LED Panel 50W backlit 60*60 General Specifications

Product type :P50 LED Panel 50 Watt 60x60: submersible - surface - suspended: The backlit LED panel is ideal for retro fixtures that provide better lighting conditions, visually comfortable and uniform illumination.: interior light: offices, schools, hospitals, banks and supermarkets.

Category
Applications

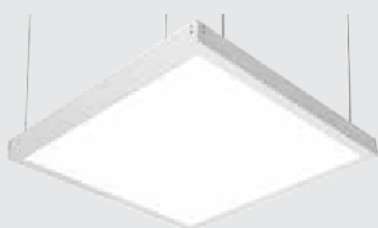

Lighting Specifications

Wattage : 50 w
 lumen : 5500 lm
 Efficacy :110 lm/w
 Power Factor : 0.95
 CRI : ≥ 80
 Color temperature : 3000 k : 4000k : 6500 k
 Rated lifetime : 30,000 / 50.000 hrs.



Physical Specifications

Body : Aluminum frame
 Finishes : Electrostatic painting
 Diffuser : PMMA / PC
 Thermal Dissipation : Passive

Color

Matt White

It includes

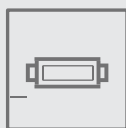

Driver
 F.P._>0.97
 THD_<15%

Electrical Specifications

Driver : hi power
 Wide input range : 100-270 V AC
 Full power output at : 70~100%
 Metal case with : IP 65
 Surge protection with : NO
 Protection functions : ---
 Frequency : 50 Hz
 Life time >30,000 hrs.and 2years warranty



INDOOR

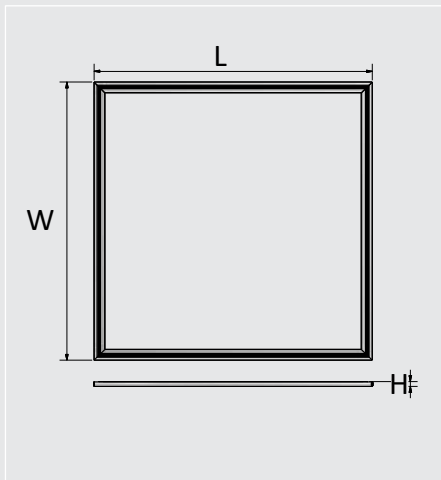

Dimensions

Mounting (mm)	Length (mm)	Width (mm)	Height	coed
submersible	595	595	25	49

Optical Specifications

Light emission : indirect light

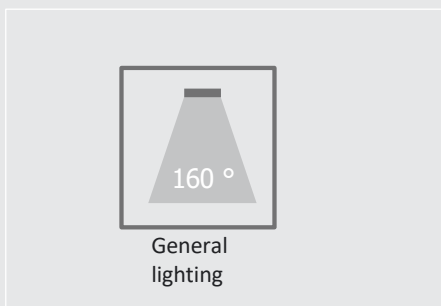

Light technical data

Warm-up time (60 %)	< 0.5 s
Starting time	< 0.5 s
Rated beam angle	160.00 °

Lifespan

Lifespan	30,000HRS
Warranty	2 Years
Number of switching cycles	20,000

Certificates & standards

Type of protection	IP44
Standards	CE
Energy efficiency class	A++
Energy consumption	50 Kwh/1000h

Temperatures & operating conditions

Ambient temperature range -10 +40°C

